



Emergency battery pack

Product Description

The EM-A/EM-B emergency battery pack works in conjunction with ballast to convert fluorescent fixtures into emergency lighting system.

Features and Benefits

- Complying to GB17945-2000*
- Initial light output more than 70% of normal output*
- Illumination duration > 90 minutes
- EMI compliant to EN 55015*
- High temperature Ni-cd battery > 4 years lifetime
- Over charging and over discharging protection

* EM-A series only

Applications

When main power fails, EM-A/EM-B emergency battery pack switches to the emergency mode, operating one lamp at a reduced lumen output for a minimum of 90 minutes. When main power is restored, the emergency pack automatically returns to the charging mode and allow the ballast to operate the lamp(s).

- Professional indoor applications (e.g. offices and hotels)
- Department stores, shops, supermarkets and public area's

Quality

We ensure optimum quality regarding:

- System supplier: As a manufacturer of both ballast and emergency battery pack, Philips ensures that optimum ballast emergency battery pack performance is maintained from the earliest development stage.
- International standards: Our emergency battery pack meet relevant rules and regulations related to safety, energy efficiency, EMC & immunity. Details can be found in the compliance and approval section.

PHILIPS

sense and simplicity

Compliances and approvals

• EMI*	EN 55015
• Safety*	GB 17945-2000
• Vibration	GB 17945-2000

* EM-A series only

Electrical installation notes

Mains operation

Rated mains voltage	220-240 V
With tolerance for safety	187-253 V
Mains frequency	50/60 Hz
LED indicator	Red, 10mA 2V _{max} .
Test switch	normally open/ push on 100mA 50V _{max} .

Technical data for design and mounting EB-C ballasts in fixtures

Temperatures

Temperature range	-10°C to +50°C
Max. T _{case}	75°C

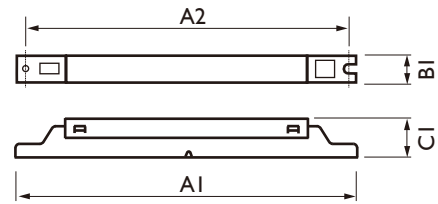

Dimensions in mm

Type	A1	A2	B1	C1
EM-A 36W TL-D 220-240V 50/60Hz	220	208	39	29
EM-A 18W TL-D 220-240V 50/60Hz	220	208	39	29
EM-B 18/36W TL-D 220-240V 50/60Hz	220	208	39	29

Technical data

Emergency Ballast	Lamp Type	Charging Current	Charging Time	Discharging Time	Initial Lumen Output
EM-A 36W TL-D 220-240V 50/60Hz	TL-D 36W	220mA	24hr	> 90 minutes	> 70%
EM-A 18W TL-D 220-240V 50/60Hz	TL-D 18W	120mA	24hr	> 90 minutes	> 70%
EM-B 18/36W TL-D 220-240V 50/60Hz	TL-D 18W/36W	110mA	24hr	> 90 minutes	> 15%

EM-A Ballast

With one lamp ballast

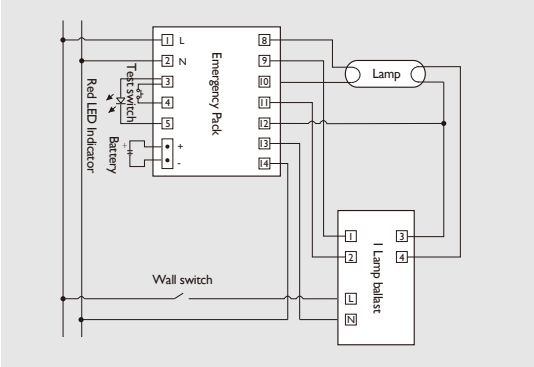

With multi-lamps ballast

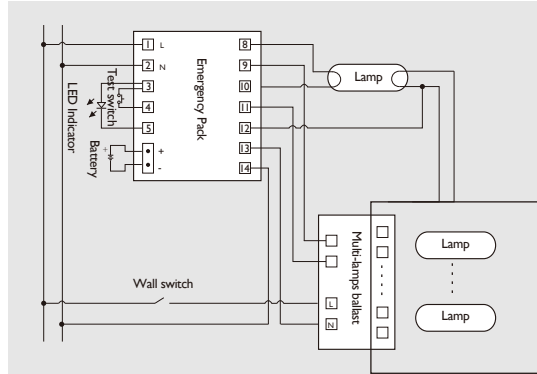

When wiring, Pin 8 and Pin 10 must be connected to the same end of the lamp, Pin 2 must be connected to the other end of this lamp. Pin 9 and 11 connected to the ballast where were connected to the lamp. The other connection of the ballast please refer to the ballast wiring diagram.

With Philips HF-S TL-D series and HF-P TL-D series ballast

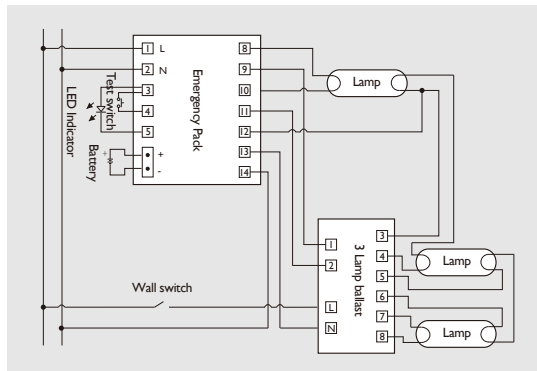
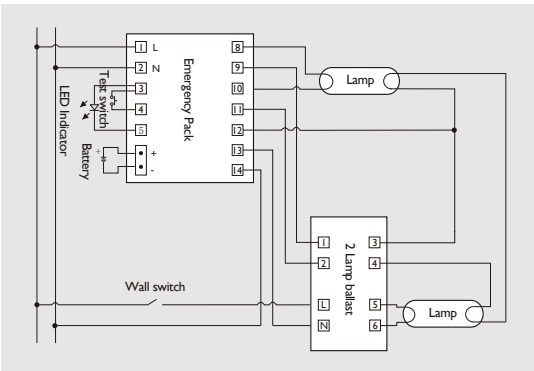

With Philips EB-C TL-D series ballast

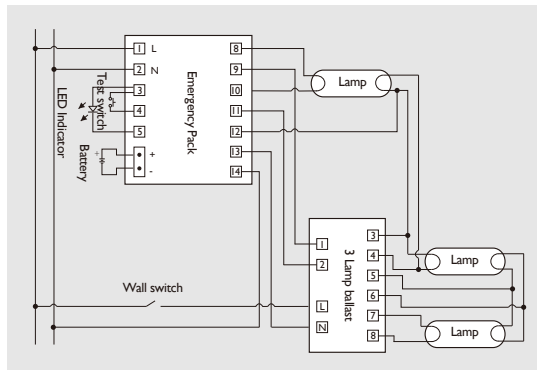
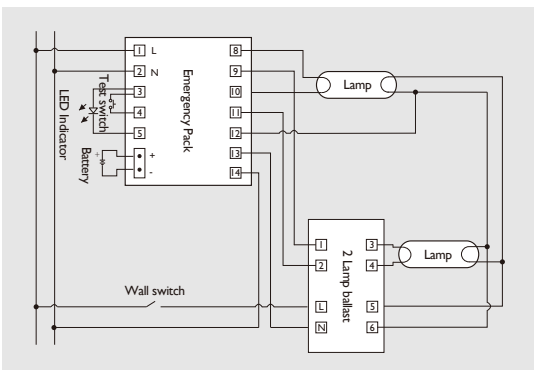

Note: The emergency pack and the ballast must be connected to the same mains.

The emergency pack must be connected to the mains directly without switch.

EM-B Ballast

With one lamp ballast

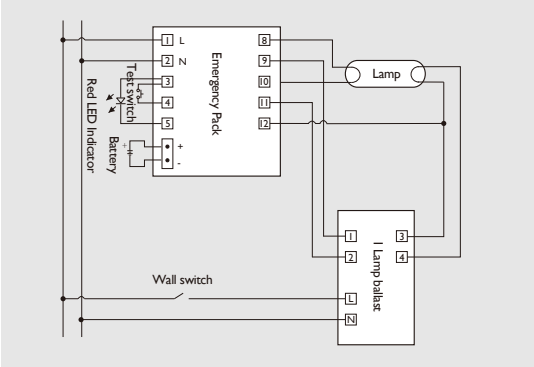

With multi-lamps ballast

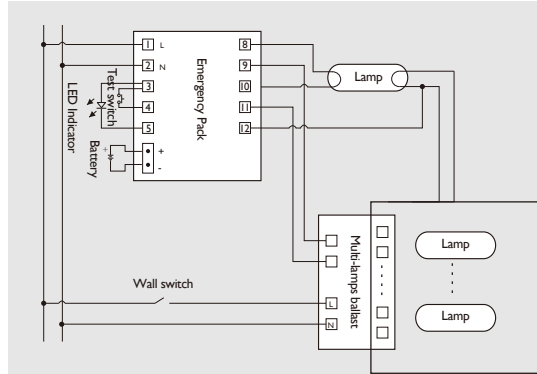

When wiring, Pin 8 and Pin 10 must be connected to the same end of the lamp, Pin 12 must be connected to the other end of this lamp. Pin 9 and 11 connected to the ballast where were connected to the lamp. The other connection of the ballast please refer to the ballast wiring diagram.

With Philips HF-S TL-D series and HF-P TL-D series ballast

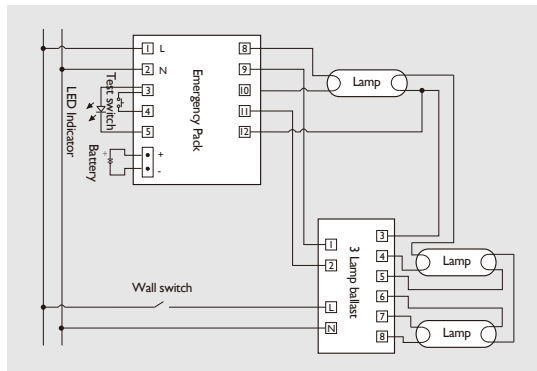
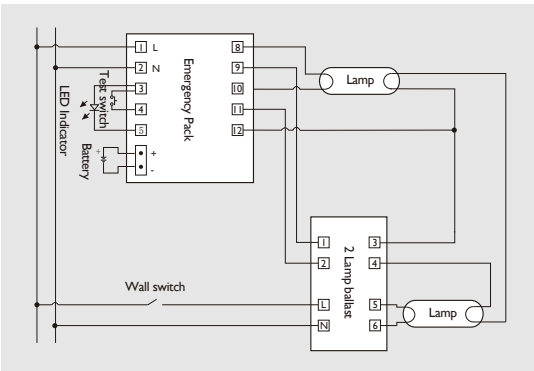

With Philips EB-C TL-D series ballast

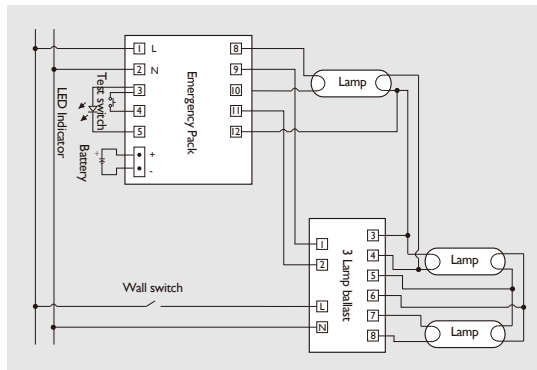
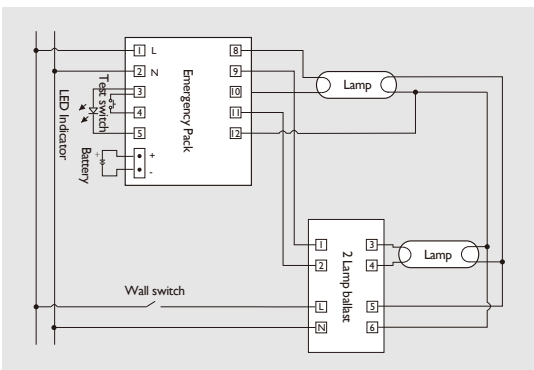

Note: The emergency pack and the ballast must connected to the same mains.

The emergency pack must be connected to the mains directly without switch.

Wire cross-section:

On the mains side	0.5 ... 1.5 mm ²
On the lamp side	0.5 ... 1.5 mm ²
Strip length	4.5 - 5 mm

Notes:

1. Data is based on a mains supply with an impedance of 400m Ω , under worst case conditions. With an impedance of 800m Ω the number of ballasts can be increased by 10%.
2. Measurements will be verified in real installations; therefore data are subject to change.
3. Use test switch in EM-B series may cause some ballast into protection mode. Turn off the wall switch for 5 seconds can release the ballast from protection mode. The test switch will not effect the normal operation and emergency operation.

Ordering and packing data

Type	weight kg	Qty bulk packing pcs	Dimensions bulk packing cm	Ordering Number
EM-A 36W TL-D 220-240V 50/60 Hz	8.32	6	32.5 x 29.0 x 12.5	913713610113
EM-A 18W TL-D 220-240V 50/60 Hz	5.74	6	32.5 x 29.0 x 16.5	913713610013
EM-B 18/36W TL-D 220-240V 50/60 Hz	11.08	20	28.5 x 26.0 x 25.5	913713610213